

## HLF127 TYPE

SPECIALIZE IN HIGH CURRENT & HIGH  
INDUCTANCE FOR SMD INDUCTORS

### CHARACTERISTICS

TEMPERATURE RISE .....	20°C
AMBIENT TEMPERATURE .....	80°C
TEMPERATURE RANGE .....	-25°C to +80°C
TERMINAL STRENGTH .....	0.15 KGf MIN.
INDUCTANCE RANGE .....	0.12μH~220μH
OUTSIDE DIM .....	12.5mm
TESTING FREQUENCY .....	1KHz/0.25V

### ELECTRICAL SPECIFICATION

ITEM	L (μH)	DCR MAX.(mΩ)	IDC1* MAX.(A)	IDC2* MAX.(A)
HLF127				
1R0N	1.0±30%	9.8	10	8.2
2R7N	2.7±30%	11.3	10	7.0
3R9N	3.9±30%	12.5	9.0	6.7
4R7N	4.7±30%	13.2	8.4	6.5
5R6M	5.6±20%	13.9	7.8	6.3
6R8M	6.8±20%	15.7	7.2	5.9
100M	10±20%	18.7	5.5	5.4
120M	12±20%	20.4	5.1	5.2
150M	15±20%	22.1	4.7	5.0
220M	22±20%	31.6	4.0	4.0
330M	33±20%	47.4	3.2	3.4
470M	47±20%	60.0	2.7	3.0
680M	68±20%	91.6	2.0	2.4
101M	100±20%	144	1.9	1.9
151M	150±20%	210	1.5	1.6
221M	220±20%	285	1.3	1.3

### CONSTRUCTION (m/m)

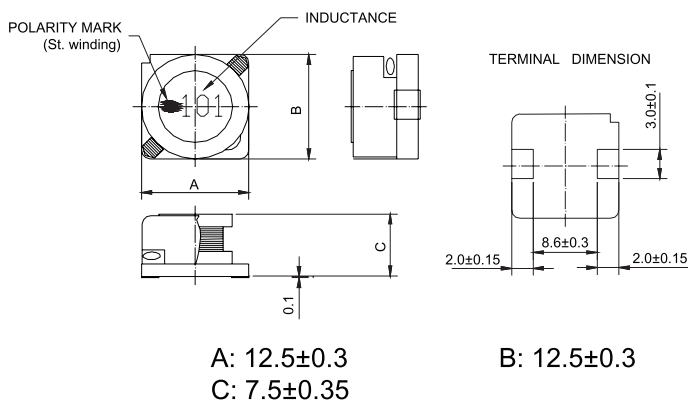

### COIL CODE

HLF127 100M

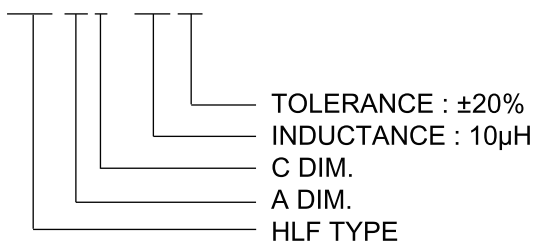

\* IDC 1: BASE ON INDUCTANCE CHANGE  
( $\Delta L/L01 \leq 15\%$ )  $\Delta \mu L = L(IDC)-LOA$

\* IDC 2: BASED ON TEMP. ( $\Delta T: 15^\circ C$ )

\* Hong can design any part to your requirements with different inductance.

\* All parameters as this content presented are subject to final specifications both sides confirmed.